

WS/GS Luftspaltdrossel nach VDE 0570 DIN EN 61558-2-20



Einphasen Luftspaltdrossel

Korrosions- und Feuchtigkeitsschutz durch komplette Vakuum-Imprägnierung, maximale Umgebungstemperatur 40°C, Isolationsklasse B, Schutzart IP 00, zum Einbau bis IP 23, **Anschlüsse von Stromstärke abhängig: auf Klemmen oder Kupferlaschen**

Single-phase reactors

Protection against humidity due and rusting by complete vacuum-impregnation, maximum ambient temperature 40°C, insulation class B, protection system IP 00, for installation up to IP 23, **connection dependent of the current: terminal or flat copper connection**

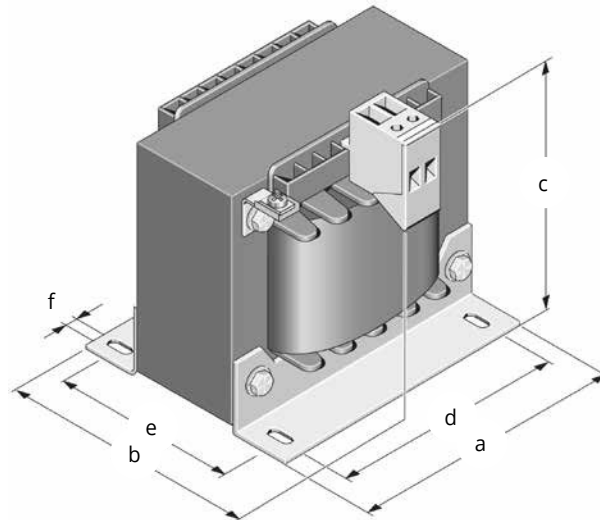

Typ type	Bauleistung core power A	a mm	b mm	c mm	d mm	e mm	f mm	Gewicht weight kg
WS / GS	0,05	78	92	106	56	50	4,8	1,6
WS / GS	0,075	84	94	96	64	50	4,8	1,7
WS / GS	0,10	84	108	96	64	61	4,8	2,1
WS / GS	0,13	105	102	111	84	62	5,8	2,9
WS / GS	0,16	105	102	111	84	62	5,8	3,0
WS / GS	0,20	105	110	111	84	70	5,8	3,5
WS / GS	0,25	120	105	121	90	70	5,8	4,5
WS / GS	0,32	120	105	121	90	70	5,8	4,6
WS / GS	0,40	120	115	121	90	84	5,8	5,8
WS / GS	0,50	120	137	121	90	102	5,8	6,8
WS / GS	0,63	150	120	157	122	84	7,0	8,2
WS / GS	0,80	150	137	157	122	101	7,0	10,2
WS / GS	1,00	174	140	181	135	96	7,0	13,0
WS / GS	1,30	174	150	181	135	106	7,0	16,0
WS / GS	1,60	174	180	181	135	136	7,0	21,0
WS / GS	2,00	195	180	196	150	130	10,0	26,2