

WT/GT Luftspaltdrossel nach VDE 0570 DIN EN 61558-2-20



Einphasen Luftspaltdrossel

Korrosions- und Feuchtigkeitsschutz durch komplette Vakuum-Imprägnierung, maximale Umgebungstemperatur 40°C, Isolationsklasse B, Schutzart IP 00, zum Einbau bis IP 23, **Anschlüsse von Stromstärke abhängig: auf Klemmen oder Kupferlaschen**

Single-phase reactors

Protection against humidity due and rusting by complete vacuum-impregnation, maximum ambient temperature 40°C, insulation class B, protection system IP 00, for installation up to IP 23, **connection dependent of the current: terminal or flat copper connection**

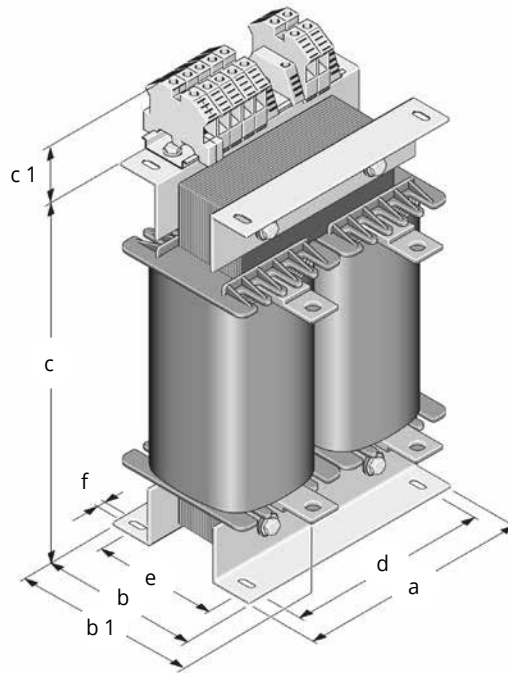

stehende Bauart / vertical design

Typ type	Bauleistung core power A	a mm	b mm	b 1 mm	c mm	c 1 mm	d mm	e mm	f mm	Gewicht weight kg
WT / GT	2,0	176	132	195	228	40 - 60	128	102	10,0	20,0
WT / GT	2,5	200	135	195	260	40 - 60	140	107	10,0	23,0
WT / GT	3,0	200	147	210	260	40 - 60	140	119	10,0	27,5
WT / GT	3,5	240	153	230	310	40 - 60	200	125	10,0	34,5
WT / GT	4,0	240	153	220	310	40 - 80	200	125	10,0	35,0
WT / GT	4,5	240	168	240	310	40 - 80	200	140	10,0	40,0
WT / GT	5,0	240	183	255	310	40 - 80	200	155	10,0	46,5
WT / GT	6,3	280	173	250	365	40 - 90	240	143	10,0	54,0
WT / GT	7,5	280	188	270	365	40 - 90	240	158	10,0	63,0
WT / GT	8,8	280	203	280	365	40 - 90	240	173	10,0	77,0
WT / GT	10,0	280	233	310	365	40 - 90	240	203	10,0	91,0